



Persee N1

With System Installation Guide



Product Brief	02
Product Specifications	03
Product Information	04
Packing List	05
System Setup Guide	06
Installation Guide	06
Pin Definitions	07
Product Dimensions	08
Safety and Handling	08
Glossary of Terms	09

1. Product Brief

Product Overview

Persee N1 is a modular all-in-one combination of a powerful computer with industry standard interfaces and a depth camera to suit a broad range of applications. The compute unit uses the popular NVIDIA® Jetson™ platform with high performance GPU to run user applications and has multiple port options including POE, USB, HDMI and storage expansion with MicroSD and M.2 slots.

The industry-proven Gemini 2 camera, based on active stereo IR technology, uses Orbbec's custom ASIC for high quality depth processing.

Persee N1 is easy to setup with Orbbec SDK and delivers highly accurate and reliable data for in-door/semi outdoor operation.

Product Features

- NVIDIA® Jetson™ Nano Quad Core ARM A57 @ 1.43 GHz
- Wide FOV (H91° x V66°) and a range of 0.15–10m
- Up to 30 fps at 1280X800 depth resolution and 1920X1080 RGB resolution
- POE (Power over Ethernet), USB, HDMI
- Memory expansion with MicroSD and M.2
- Multi-camera synchronization and IMU
- 0°C ~ 40°C indoor/semi-outdoor operation

2. Product Specifications

Parameter	Properties
Model	P13200-0230
Camera	Gemini 2
Range	0.15m-10m
Depth Resolution Framerate	Up to 1280 x 800 @ 30FPS
RGB Resolution Framerate	Up to 1920 x 1080 @ 30FPS
Depth FOV	H91° x V66°
RGB FOV	16:9 H86° x V55° 4:3 H63° x V50°
Rating	Class 1 Laser Product
SDK	Orbbec SDK
Processor	NVIDIA Jetson Nano Quad Core ARM A57 @ 1.43 GHz Orbbec ASIC for Depth Processing
RAM	4GB
Storage	16GB eMMC with M.2 M key expansion slot
Micro SD	Up to 128GB
Display Output	HDMI x 1, DisplayPort x 1
Ethernet	RJ45 Gigabit Ethernet, supports 802.3 at PoE
USB	USB 3.0 Type A x 2 USB 2.0 Type A x 2 USB 3.0 Type C Male x 1 (Camera) USB 2.0 Type-C Female x 1 (System Installation)
UART	6-Pin
GPIO	40-Pin
RTC	CR2032, 3V
Operating System	Linux
Power	Power Adapter (12V/3A)
Operating Environment	0°C ~ 40°C, Indoor/Semi-Outdoor; 5%-95%RH
Power Consumption	Average 12W
Dimensions (W*H*D)	200mm x 100mm x 90mm
Weight	986g
Certifications	CE, Class 1, FCC, IC, PSE, REACH, RoHS, WEEE

3. Product Information

3.1 Product Images



Persee N1 Front View



Persee N1 Rear View



Persee N1 without Camera

3.2 Product Interfaces

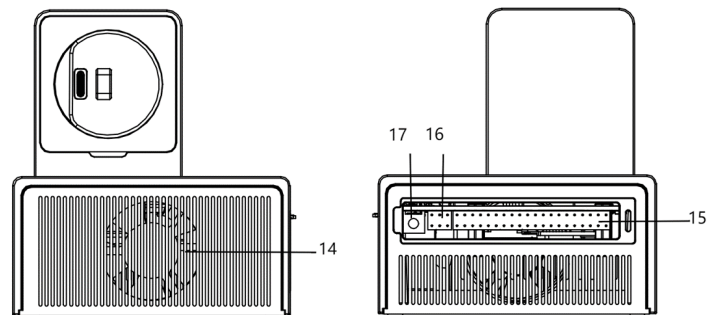
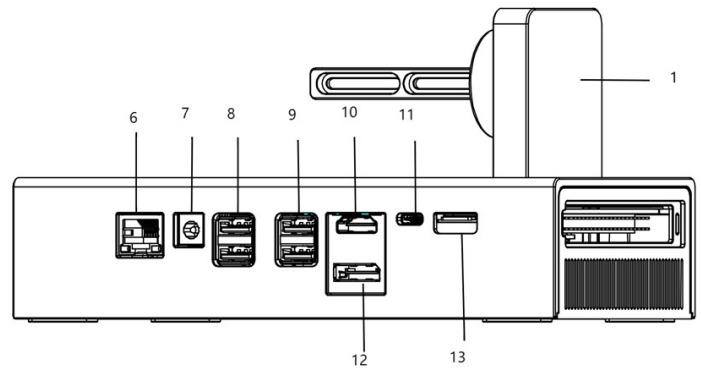
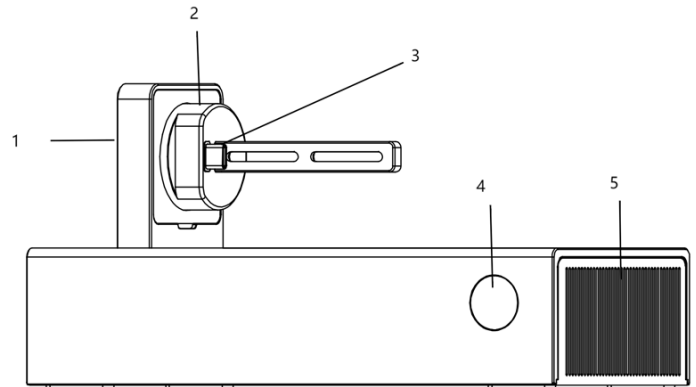

Product Information (continued from previous page):

1	Camera Support
2	Adjustable Camera Support Bracket
3	USB 3.0 Type-C
4	Power Button
5	Air Vent
6	Gigabit Ethernet
7	Power Input
8	USB 2.0 x 2
9	USB 3.0 x 2
10	HDMI

11	USB 2.0 Type-C for System Installation Only
12	DisplayPort
13	MicroSD Expansion Slot
14	Fan and Air Vent
15	40-Pin GPIO
16	6-Pin UART
17	Force Recovery Button

4. Packing List

- Persee N1 Compute Base x 1
- Gemini 2 x 1
- Mounting Screws x 2
- Power Adapter x 1
- HDMI Cable x 1

5. System Setup Guide

5.1 Preparing for System Setup

Configuration Requirements for Computers

- a. Ubuntu operating system
- b. High-speed USB 2.0 or USB 3.0 interface
- c. Download Orbbec provided system image

[Click to Download Persee N1 System Image](#)

5.2 Setup Procedure

- a. Use a USB Type-C cable to connect Persee N1 with an Ubuntu based computer.
- b. Connect the power supply to Persee N1
- c. Long press the 'Force Recovery' button
- d. While holding the 'Force Recovery' button, press the power button on Persee N1
- e. Release the 'Force Recovery' button until 'lsusb' command shows the device is recognized as 'NVIDIA Corp. ...'
- f. Run `./nvmflash.sh` script in Terminal to start updating
- g. Retry procedures a-f if needed

Please note: the installation process will erase and format all existing information saved on the board, please backup before starting the system installation procedure.

6. Installation Guide

Mount the camera to the compute base with the provided screws as shown below.

Note: Use outside of the specified conditions could cause the device to fail and/or function incorrectly. These conditions are applicable for the environment immediately around the device under all operational conditions.

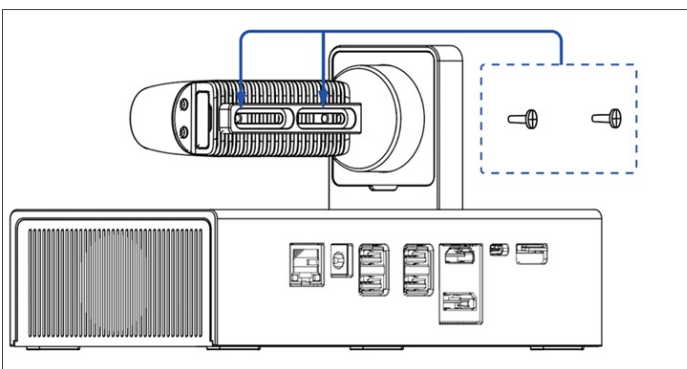

7. Pin Definitions

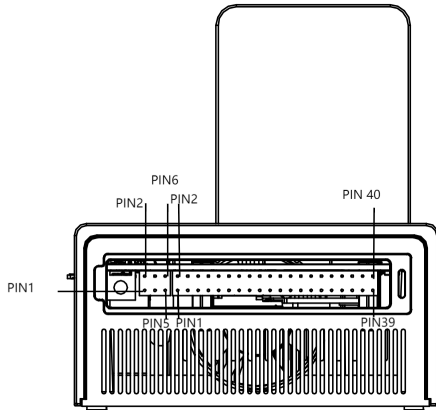

UART (6-Pin)

Pin#	Definitions
PIN 1	SYS_RST
PIN 2	GND
PIN 3	UART_RXD
PIN 4	GND
PIN 5	UART_TXD
PIN 6	GND

GPIO (40-Pin)

Pin	Definitions	Sysfs GPIO	Pin	Definitions	Sysfs GPIO
PIN 1	3.3V DC		PIN 2	5.0V DC	
PIN 3	I2C_2_SDA (I2C BUS 1)		PIN 4	5.0V DC	
PIN 5	I2C_2_SCL (I2C BUS 1)		PIN 6	GND	
PIN 7	AUDIO_MCLK	GPIO216	PIN 8	UART_2_TX (/dev/ttyTHS1)	
PIN 9	GND		PIN 10	UART_2_RX (/dev/ttyTHS1)	
PIN 11	UART_2_RTS	GPIO50	PIN 12	I2S_4_SCLK	GPIO79
PIN 13	SPI_2_CLK	GPIO14	PIN 14	GND	
PIN 15	LCD_TE	GPIO194	PIN 16	SPI_2_CS1	GPIO232
PIN 17	3.3V DC		PIN 18	SPI_2_CS0	GPIO15
PIN 19	SPI_1_MOSI	GPIO16	PIN 20	GND	
PIN 21	SPI_1_MOSO	GPIO17	PIN 22	SPI_2MISO	GPIO13
PIN 23	SPI_1_CLK	GPIO18	PIN 24	SPI_1_CS0	GPIO19
PIN 25	GND		PIN 26	SPI_1_CS1	GPIO20
PIN 27	I2C_1_SDA		PIN 28	I2C_1_SCL (I2C BUS 0)	
PIN 29	CAM_AF_EN	GPIO149	PIN 30	GND	
PIN 31	GPIO_PZ0	GPIO200	PIN 32	LCD_BL_PWM	GPIO168
PIN 33	GPIO_PE6	GPIO38	PIN 34	GND	
PIN 35	I2S_4_LRCK	GPIO76	PIN 36	UART_2_CTS	GPIO51
PIN 37	SPI_1_MOSI	GPIO12	PIN 38	I2S_4_SDIN	GPIO77
PIN 39	GND		PIN 40	I2S_4_SDOU	GPIO78

8. Product Dimensions

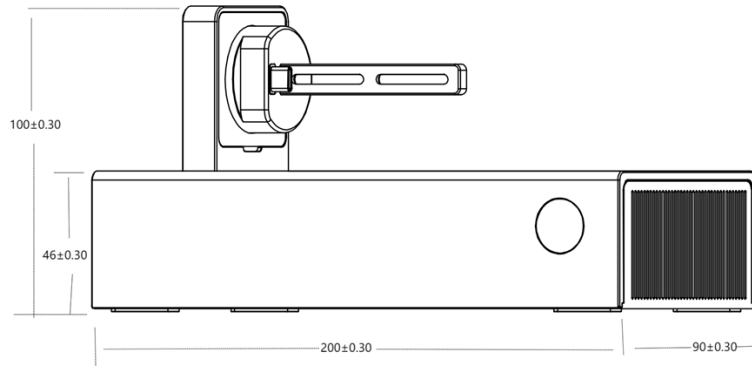

9. Safety and Handling

9.1 Safety Precautions

1. Follow the camera operation instructions. Improper operation may cause damage to internal components.
2. Do not drop or subject the camera to external force.
3. Do not attempt to modify the camera as such modifications may cause permanent damage or inaccuracies.
4. The camera temperature may increase during long periods of continuous usage.
5. Do not touch the lens. Fingerprints on the lens may affect image quality.
6. Keep the product beyond the reach of children or animals to avoid accidents.
7. If the camera is not recognized, check whether the camera is securely inserted to the USB Type-C port on the compute base or reinsert the camera for reconnection.
8. This product uses a Class 1 laser. Looking at the laser for more than 20s is not recommended.

9.2 Cleaning

To clean the camera body, use a clean, soft cloth to wipe away dust and debris. To remove stains from the lens, use a lens cleaning solution and carefully wipe with a clean, soft, lint-free cloth.

- Do not use alcohol, gasoline, kerosene, or other corrosive or volatile solvents to clean the camera.
- Do not use pressure washers or hoses to spray the camera.

9.3 Storage

When not in use, store the camera in a cool, dry, and well-ventilated indoor location. Avoid leaving the camera outdoors for extended periods to prevent damage from rain, snow, or other harsh conditions.

- Disconnect the power supply before storing the camera.
- Do not point the lens directly at the sun; avoid exposing the lens to strong light sources for extended periods.

10. Glossary of Terms

Term	Definition
D2C	Depth to Color function maps each pixel on a depth map to the corresponding color image according to the intrinsic and extrinsic parameters of depth camera and color camera.
Depth	Depth video streams are like color video streams except each pixel has a value representing the distance away from the sensor instead of color information.
Depth Camera	Includes the external interface and the depth imaging module, which is generally composed of the infrared projector, infrared camera, and the depth computing processor.
FOV	Field of View (FoV) describes the angular extent of a given scene that is captured by a camera, which can be measured in horizontal, vertical, or diagonal.
I2C	I2C bus refers to a kind of simple bidirectional two-wire synchronous serial bus developed by Philips. It can be used for transferring information among devices connected to the bus with two wires.
IR Camera	Infrared camera.
IR Flood	IR floodlights are used to illuminate the environment.
ISP	Image signal processor, which is used for image post-processing.
MIPI	Mobile Industry Processor Interface (MIPI) is an open standard and specification formulated by the MIPI Alliance for mobile application processors.
PCBA	Circuit board that includes the depth computing processor, memory, and other electronic devices.
Point Cloud	A point cloud is a discrete set of data points in space.
SoC	System on Chip, an integrated circuit (IC) that integrates all components of a computing system.
TBD	To Be Determined. In the context of this document, information will be available in a later revision.

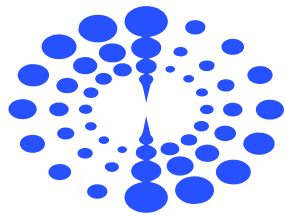

ORBBEC